

**ATHLON**  
RIDICULOUSLY GOOD OPTICS

**ARES HLR  
2.5-15x42**

**ARES HLR HD  
4-24x50**

**RETICLES:**

AHMC1 FIBER DOT IR MOA

APLR-H2 IR MOA

APRS-H2 IR MIL

**SECOND FOCAL PLANE**

**RIFLESCOPE  
USER MANUAL  
& CARE INSTRUCTIONS**



# Table of Contents

- 1) Mounting Your Athlon Riflescope
  - a) Scope Dimensions
  - b) Focusing the Scope
  - c) Adjustment for Maximum Eye Relief
  - d) Bore Sighting
  - e) Zeroing the Scope
  - f) Base Adjustment
- 2) Reticles
- 3) Maintaining Your Riflescope
- 4) Trouble Shooting Tips

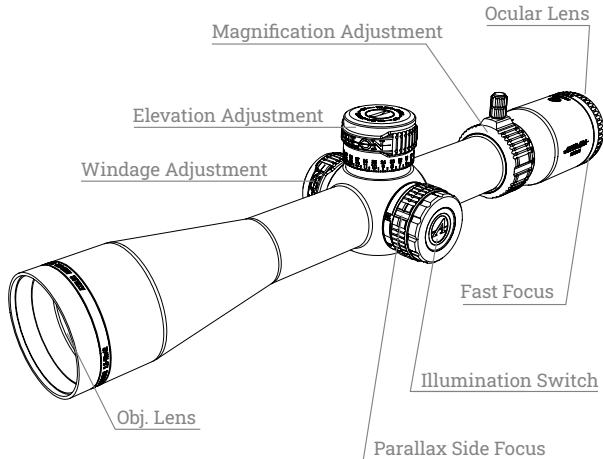

*Congratulations on purchasing an Athlon Riflescope. Athlon is the ancient Greek word for "Prize" or "Medal." We think that with the purchase of your Athlon product you have won the best "prize" on the market today. Great Quality while still being a great value.*

## 1. MOUNTING YOUR ATHLON RIFLESCOPE

**CAUTION: BEFORE MOUNTING A RIFLESCOPE BE SURE THAT THE FIREARM IS NOT LOADED, HAS ACTION OPEN AND THE MUZZLE POINTING IN A SAFE DIRECTION. SAFE FIREARM HANDLING PROCEDURES NEED TO BE PRACTICED AT ALL TIMES.**

To achieve the best performance from your rifle and your Athlon Scope, your scope must be mounted properly. If you are unfamiliar with proper procedures to mount a scope, we highly recommend to have the scope mounted by a qualified gunsmith

Athlon recommends you use high quality, appropriately sized rings and bases matched to your rifle when mounting your scope on the rifle. Please note that most ballistic charts use 1.5" as the standard mounting height for scopes when publishing ammunition information. Higher mounting height will have an effect on the impact point of the bullet. Mount your scope as low as you can without it touching the rifle or impeding the operation of the action of the gun. Attach bases and the bottom of the rings to your rifle. Be sure to follow the manufacturer instructions supplied with the rings and mounting base.

## a) SCOPE DIMENSIONS

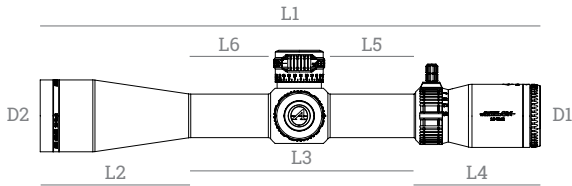

RIFLESCOPE MODEL	L1	L2	L3	L4	L5	L6	D1	D2
2.5-15x42 SFP	13.8"	4.1"	6.1"	3.7"	2.3"	2.1"	1.7"	1.9"
4-24x50 SFP	13.2"	3.9"	5.6"	3.7"	2.3"	1.6"	1.8"	2.2"

## b) FOCUSING THE SCOPE

The purpose of the Fast Focus eyepiece is to focus the reticle in the scope to your eyes. For a fast focus eyepiece, just simply rotate the fast focus ring at the end of the eyepiece in either direction to get a perfect clear reticle while looking through the scope pointing at a flat plane surface. This is important to do prior to mounting.

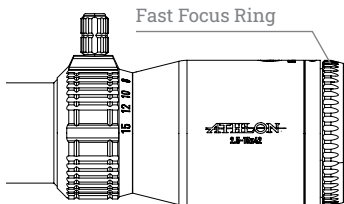

## c) ADJUST FOR MAXIMUM EYE RELIEF

- You need to adjust the scope for maximum eye relief before tightening of the scope rings, to avoid injury from recoil.
- With the scope on highest magnification, move the scope forward as far as possible in the rings.
- With the rifle in normal shooting position, look through the scope and slowly slide the scope back towards you. When you finally see the full field of view with sharp and clear edges, stop. Make sure the scope has not rotated so the reticle is tilted.
- Rotate the scope until the elevation dial is at the top of the scope and the vertical cross-hair of the reticle matches the vertical axis of the rifle. This will be easier if you find a vertical reference such as the straight edge of a building or a telephone pole. Make sure the scope has not moved forward or backward while doing this.
- Tighten the rings per the manufacturer's instructions.

## d) BORE SIGHTING

Bore sighting is a preliminary procedure to achieve proper alignment of the scope with the rifle's bore.

- The initial bore sighting of the scope can be at short range of 50 yards. This is easier than trying to bore sight at 100 yards and will get you on the paper at that distance, so to save time and money at the shooting range. We highly recommend using a bore sighter, but make sure to follow the manufacturer's instructions.

- ii. This can also be done by removing the bolt and sighting through the rear of the action. Make sure the rifle is placed solidly on a bench and the bolt is removed. You can then sight through the action and center the bore and target inside the barrel. (Note: Many ring and base sets have some kind of windage adjustments. Use these external adjustments first before using the scopes internal windage adjustments). With target centered in the bore, make windage and elevation adjustments until the reticle crosshair is also centered over the bulls eye.

## e) ZEROING THE SCOPE

IF A LASER BORE SIGHTING OR ANY OTHER SIMILAR DEVICE INSIDE THE BORE WAS USED, IT MUST BE REMOVED BEFORE FIRING. AN OBSTRUCTED BORE CAN CAUSE SERIOUS DAMAGE TO THE GUN AND POSSIBLE INJURY TO THE SHOOTER.

- i. Ideally set the rifle on a two or three holding point gun rest, and then fire three rounds at a target 100 yards away. Observe the bullet holes on the target and calculate how far those bullet holes are off the center of the target, and then adjust windage and elevation knobs to move the center of the reticle up, down, left or right. Fire another three rounds, then observe and adjust. Repeat this step as necessary until the three round bullet holes are perfectly aligned with the center of the target.

- ii. Setting Windage and Elevation and locking your zero stop

Athlon Ares HLR scope has a removable elevation turret knob secured by a single top screw. Once a rifle has been zeroed in, simply remove the screw and remove the turret knob. After you remove the elevation knob, you will see a 1/8 inches thick brass plate inside. Just simply tighten three side screws of the plate while making sure the notch of the plate touches the shallow groove of the spinner (see the illustration), so the plate will not turn any further clockwise (down direction). Then put the elevation turret knob back on with zero line aligned with the vertical mark below the turning knob. Lastly, tighten the screw to lock the knob in. There is no zero stop function for windage knob.

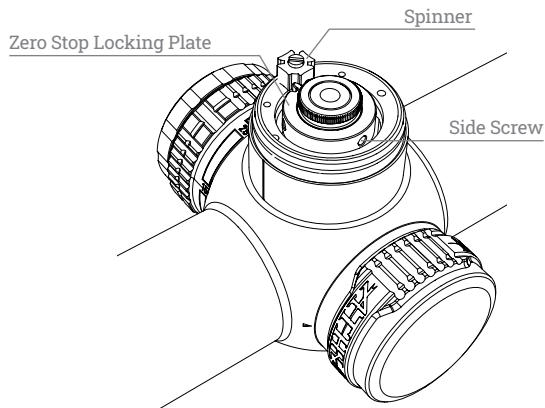

By zeroing the rifle at 100 yards, the shooter can calculate how many clicks of adjustment are needed for different distances or wind conditions. After shooting, the shooter can quickly turn the elevation knob clockwise (down direction) and go back to the zero position once the knob cannot be turned any further. **DO NOT OVERTURN THE ELEVATION KNOB ONCE IT STOPPED.**

Center Screw of Elevation Turret Knob  
(Capped Windage Turret)

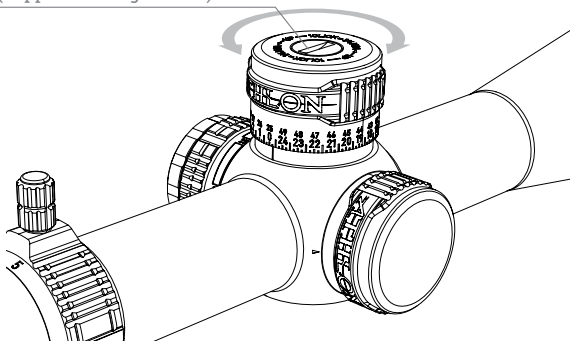

Athlon Ares HLR scopes have several options available, 1/4 MOA, and 1/10 MIL for the click values of elevation and windage adjustment depending on different configurations of scopes and reticle selections. MOA, a unit of angular measurement, is defined as a minute of angle, a minute is 1/60th of one degree and 1/21600th of a circle. One MOA equals 1.047-inch (rounded down to one inch) at 100 yards, two inches at 200 yards and to ten inches at 1000 yards. 1/4

MOA per click takes four clicks to move point of impact one inch at 100 yards. MIL, which is short for Milliradian and another unit of angular measurement, is defined as 1/1000th of a radian (6.2832 radians in a circle) and 1 MIL equals to 3.438 moa and 3.6 inches at 100 yards, 7.2 inches at 200 yards, and to 36 inches at 1000 yards. 1/10 MIL per click takes 10 clicks to move point of impact 3.6 inches at 100 yards. Knowing the click value and the number of clicks needed for different distance is critical to dial in elevation and windage adjustments based on the rifle ballistics and wind velocity.

## f) BASE ADJUSTMENT

Athlon riflescope reticle comes centered from the factory. If you need to make additional adjustments when initially sighting in your scope, many ring and base setups allow you to adjust windage at the base mount. If possible, use these adjustments for initial windage change. Though not usually necessary, you can correct the elevation adjustment by replacing the mounting base with an offset 20+ MOA scope rail.

## 2. RETICLES

The reticles in your Athlon Ares HLR rifle scope are second focal plane (SFP). This is according to where the reticle is located within the rifle scope.

Second focal plane (SFP) reticles are located near the eyepiece behind the image erecting and magnifying lenses. This style of reticle does not visually change in size when you change the magnification. The advantage of an SFP reticle is that it always maintains the same ideal visual appearance. If your reticle style has subtensions that help you determine where to aim depending on distance from target and windage, it will have been engineered for only one particular magnification.

## ILLUMINATION

Athlon Ares HLR riflescopes offer variable brightness settings. Press and hold the button to turn on illumination. Cycle brightness settings by pressing the button once. Press and hold again to turn off illumination. The illumination is powered by a lithium CR2032 3V battery. Remove the battery chamber cap by turning it counter-clockwise and then set the battery with the positive (+) side facing up. Reinstall the cap by turning it clockwise, **DO NOT OVER-TIGHTEN**.

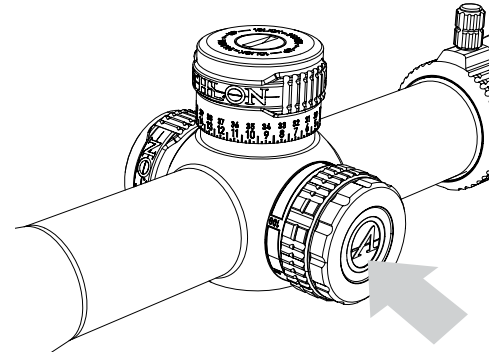

Please see the following reticle subtensions and find more details from the reticle instruction manual to fully utilize the features and maximize the performance of the reticle design. You can download the reticle instruction manual from the product specifications tag of the product page on: [www.athlonoptics.com](http://www.athlonoptics.com)

## AHMC1 FIBER DOT IR MOA

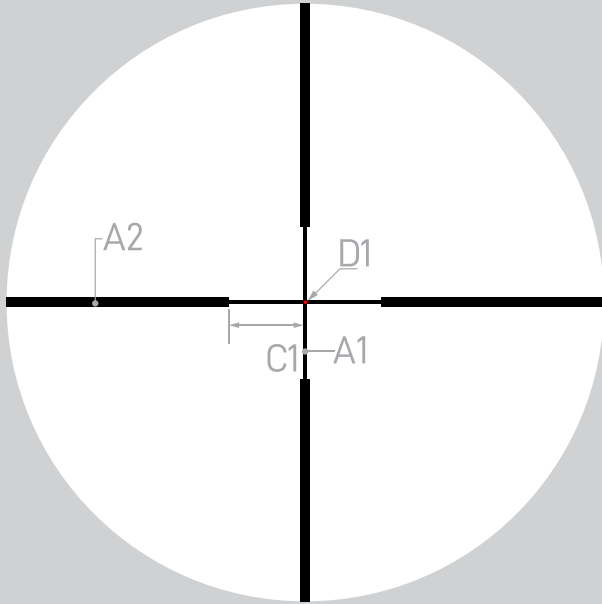

### SUBTENSIONS IN MOA 2.5-15x42

A1	A2	C1	D1
0.3	1.2	20	0.3

Valid @ 15x

### SUBTENSIONS IN MOA 4-24x50

A1	A2	C1	D1
0.25	1	10	0.25

Valid @ 16x

## APLR-H2 IR

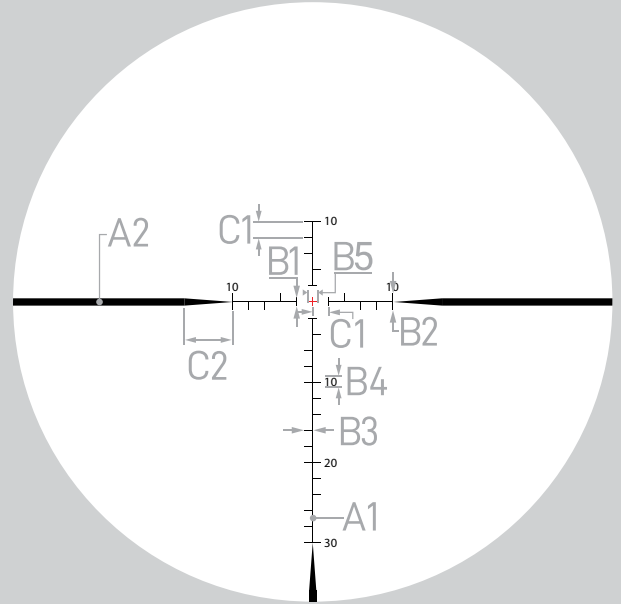

### SUBTENSIONS IN MOA

A1	A2	B1	B2	B3
0.12	0.9	1	2	1

B4	B5	C1	C2
1	1	2	6

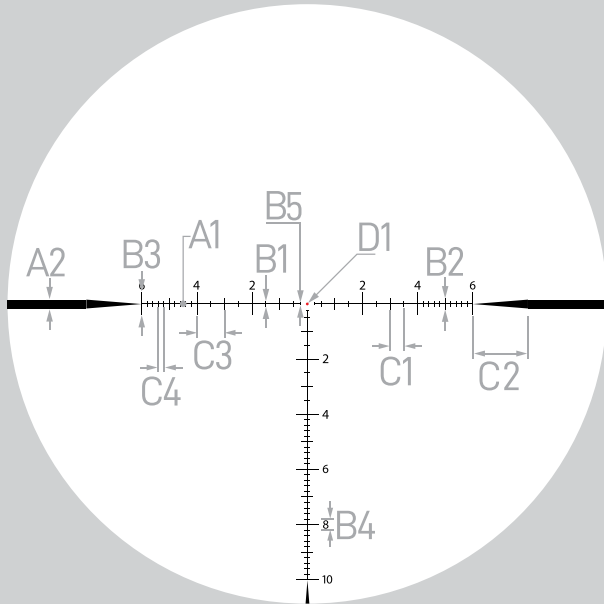

**SUBTENSIONS IN MIL**

A1	A2	B1	B2	B3	B4
0.03	0.3	0.2	0.4	0.8	0.3
B5	C1	C2	C3	C4	D1
0.1	0.5	2	1	0.2	0.1

### **3. MAINTAINING YOUR RIFLESCOPE**

Disassembling or cleaning the scope internally will void the warranty. If the scope requires repairs, please refer to the warranty section for complete instructions.

The external optical surfaces should occasionally be wiped clean. Use the lens cloth provided or an optical quality lens paper to wipe out dust or dirt on the external lens surface. If large sand particles or heavy dirt contamination is observed, remove using soft brush or by blowing them away. Apply lens cleaning liquid before wiping off. Always keep the protective lens covers in place when the scope is not in use to avoid dust collecting on the surface of the lenses. Store the unit in a low-humidity environment.

#### 4. TROUBLE SHOOTING TIPS - INACCURACY ISSUES

- i. Check scope mounting and make sure there is no movement when pulling the scope by hands. Tighten the mounts if there is any movement observed.
- ii. Use a benchrest or bags to support the rifle stock. Take care not to use supports on the barrel when making windage and elevation adjustments. This will help eliminate movement.
- iii. It is recommended using the same type of ammunition with same weight.
- iv. Check your rifle stock, as a loose stock changes the point of impact.
- v. Make sure your rifle chamber and barrel are clean.
- vi. Make sure rifling of the barrel is not damaged and no excessive grease inside the barrel.
- vii. For any technical related questions, please contact Athlon Optics at [contact@athlonoptics.com](mailto:contact@athlonoptics.com) or call toll free 1-855-913-5678.

#### THE ATHLON GOLD MEDAL LIFETIME WARRANTY\*

Demand the most from your equipment. When things go unexpectedly or accidents happen, rest assured, Athlon Optics carry a lifetime transferable warranty. Athlon guarantees to repair or replace your product if damaged through normal use. No charge; No receipt; No Registration required.

***\*This warranty does not cover damages caused by deliberate damage, misuse, theft or maintenance provided by someone other than the Athlon Authorized Service Department.***

***\*This warranty does not cover any optional accessories offered in the package; including sunshade, lens cap, and throw lever.***



## **WARNING**

• **INGESTION HAZARD:** THIS PRODUCT CONTAINS A BUTTON CELL OR COIN BATTERY. • **DEATH OR SERIOUS INJURY CAN OCCUR IF INGESTED.** • A SWALLOWED BUTTON CELL OR COIN BATTERY CAN CAUSE **INTERNAL CHEMICAL BURNS** IN AS LITTLE AS **2 HOURS.** • **KEEP NEW AND USED BATTERIES OUT OF REACH OF CHILDREN.** • **SEEK IMMEDIATE MEDICAL ATTENTION** IF A BATTERY IS SUSPECTED TO BE SWALLOWED OR INSERTED INSIDE ANY PART OF THE BODY. FOR TREATMENT INFORMATION CALL: **1-800-498-8666.** **BATTERY TYPE: CR2032.** NOMINAL VOLTAGE: 3.0V 10MAH



## **WARNING**

REMOVE AND IMMEDIATELY RECYCLE OR DISPOSE OF USED BATTERIES ACCORDING TO LOCAL REGULATIONS AND KEEP AWAY FROM CHILDREN. **DO NOT** DISPOSE OF BATTERIES IN HOUSEHOLD TRASH OR INCINERATE. EVEN USED BATTERIES MAY CAUSE **SEVERE INJURY OR DEATH.**

**CALL A LOCAL POISON CONTROL CENTER FOR TREATMENT INFORMATION.** NON-RECHARGEABLE BATTERIES ARE NOT TO BE RECHARGED. **DO NOT** FORCE DISCHARGE, RECHARGE, DISASSEMBLE, HEAT ABOVE 160°F OR INCINERATE. DOING SO MAY RESULT IN INJURY DUE TO VENTING, LEAKAGE OR EXPLOSION RESULTING IN CHEMICAL BURNS. DO NOT COOL BELOW -40°F. ENSURE THE BATTERIES ARE INSTALLED CORRECTLY ACCORDING TO POLARITY (+ AND -). REMOVE AND IMMEDIATELY RECYCLE OR DISPOSE OF BATTERIES FROM EQUIPMENT NOT USED FOR AN EXTENDED PERIOD OF TIME ACCORDING TO LOCAL REGULATIONS.

ALWAYS COMPLETELY SECURE THE BATTERY COMPARTMENT. IF THE BATTERY COMPARTMENT DOES NOT CLOSE SECURELY, STOP USING THE PRODUCT, REMOVE THE BATTERIES, AND KEEP THEM AWAY FROM CHILDREN.

**SHARP, TIGHT  
AND PRICED  
JUST RIGHT!**

Toll free: 1-855-913-5678

[contact@athlonoptics.com](mailto:contact@athlonoptics.com)

10817 RENNER BLVD,  
LENEXA, KS 66219

**ATHLONOPTICS.COM**